

NAME _____

(1) Write & define Ohm's Law (*i.e. list the algebraic relationship, define all terms and provide the units for each*).

(2) In accordance with Ohm's Law, for a fixed input voltage, if the circuit resistance is decreased – what happens to the current?

(3) In accordance with Ohm's Law, for a fixed circuit resistance, if the voltage is decreased – what happens to the current?

(4) Explain Kirchoff's Voltage law for the summation of voltage drops versus voltage increases, for any given circuit loop.

(5) Explain Kirchoff's Current law for any given circuit node.

(6) Convert the following from Amperes to milli-Amperes:

a. (0.125 Amperes) = _____

b. (1.08450 Amperes) = _____

c. (23.12535 Amperes) = _____

(7) Convert 343 milli-Amperes to Amperes?

(8) How many Amperes are there in one milli-Ampere?

(9) With a Vernier caliper, measure the ID and OD of the following pipe section:

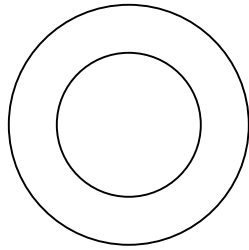

(10) Calculate the wall thickness of the pipe section in problem #9 based on your results for problem #9.

(11) To how many decimal places can an ordinary centi-meter stick be estimated?

(12) To how many places can a Vernier caliper be read?

(13) A resistor is color coded – red, blue, green & gold – from left to right. What is its magnitude?

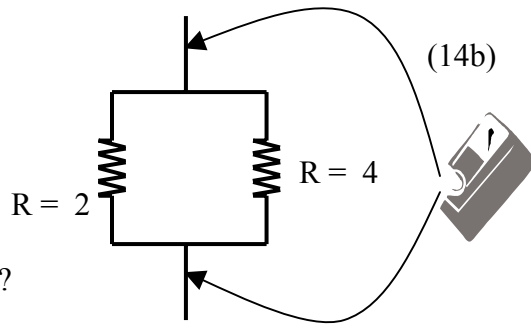
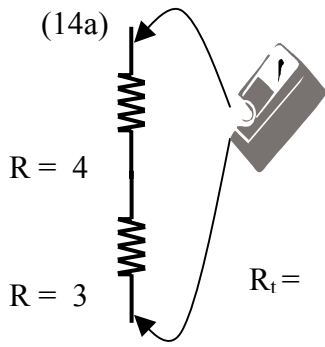

Each multi-meter to the left is set to measure resistance - list what each multi-meter would show.

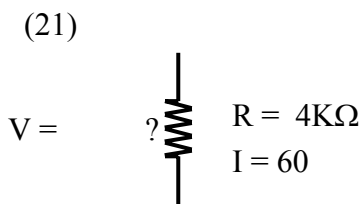
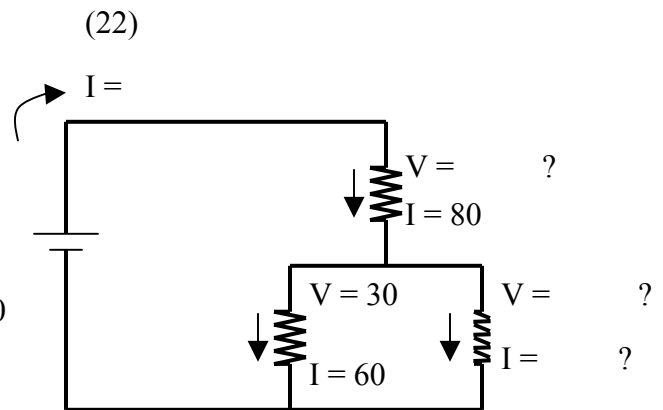
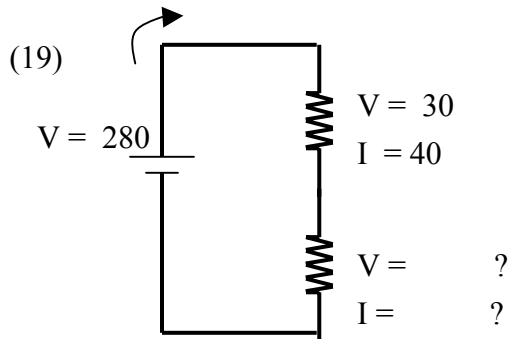
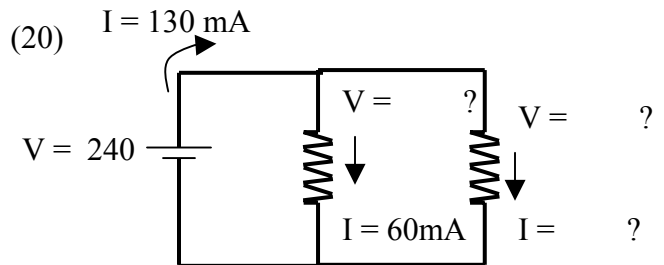
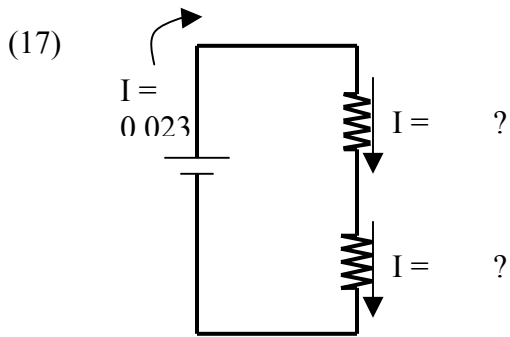
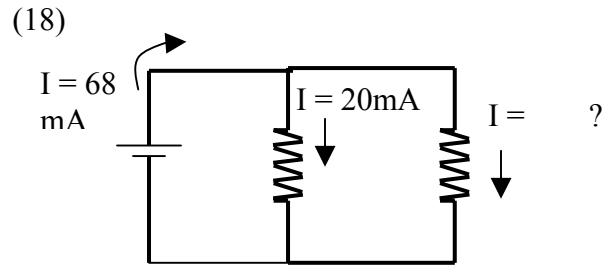
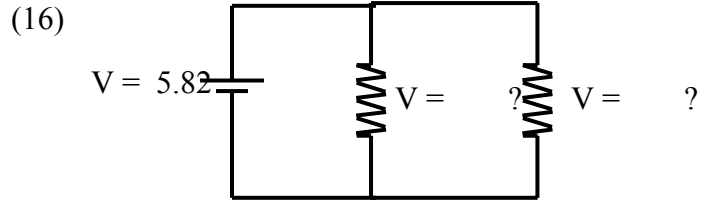
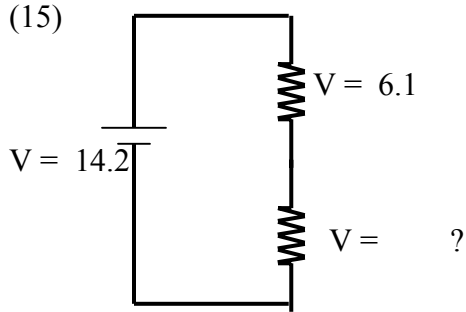

- (23) Define a volt in terms of coulombs (*a unit of charge*) and joules (*a unit of energy*).
- (24) If an ampere is a measurement of the amount of charge flowing in a conductor per unit time what are the units of one ampere?
- (25) If a household hair dryer uses 15 amps at 110 volts - how much power is consumed by the hair dryer?
- (26) In the typical US residence, voltage is supplied to the house at both 120 Volts and 240 Volts AC. If an electrician was wiring a baseboard heater, so as to minimize the current draw through the supply wires, which voltage supply would he use and why?
- (27) When a car battery is “jumped” with another car battery – how are the cables run - in series or in parallel? Why? What (*conventional*) colors of the supply battery would you connect to what (*conventional*) colors on the “dead-car” battery?
- (28) The typical outlet in an American home is rated at 110 to 120 Volts. Is this supplied on an alternating or direct current basis? What are the abbreviations for these two types of current?
- (29) If a resistor is advertised at $1250\ \Omega$ with a silver tolerance band – what’s is the range of allowable resistance values (*in Ohms*) for this resistor?
- (30) Draw a schematic representation of a direct current voltage source.

- (31) Draw a schematic representation of a three parallel resistors in series with two separate series resistors.
- (32) When measuring something, what does Ω stand for?
- (33) Why is a lamp holder not necessarily a mandatory component to light a light bulb? Sketch the necessary circuit (*schematically*) to accomplish this (*i.e. to light a light bulb without a lamp holder*). Label the contact points of the light bulb accordingly.
- (34) What component in a mechanical (*fluid*) circuit is analogous to a battery (*voltage source*) of an electrical circuit?
- (35) What quantity in a mechanical fluid circuit is analogous to Amperes in an electrical circuit?
- (36) What is the normal polarity of a terminal colored black (*as opposed to red*) on a battery?
- (37) Nuclear power (*from Uranium or Plutonium*) generates heat from what type of reaction – combustion, fission or fusion?

- (38) In a single loop mechanical (*fluid*) circuit - if an additional parallel piping run is added, does the overall resistance to current flow increase or decrease? Why?
- (39) How is an ammeter hooked up with the source voltage – in series or in parallel?
- (40) How is a voltmeter hooked up relative to a measured input or output – in series or in parallel?
- (41) Write a mathematical expression for the total value (R_T) of four resistors (R_1 , R_2 , R_3 & R_4) in series.
- (42) Write a mathematical expression for the total value (R_T) of four resistors (R_1 , R_2 , R_3 & R_4) in parallel.
- (43) What is the total value (R_T) of two resistors (R_1 , & R_2) in parallel, when $R_1 = 4$ Ohms and $R_2 = 8$ Ohms.
- (44) What is the Greek letter that symbolizes resistance (*give your answer in English and also write the Greek letter*).
- (45) If the total value (R_T) of four resistors (*in series*) is 180 Ohms and $R_1 = R_2 = 40$ Ohms and $R_3 = 45$ Ohms what is the value of R_4 ?
- (46) What does the symbol “~” mean on a voltmeter?

- (47) If your utility bill indicates that you used 900 Kilowatt-Hours of electricity and the cost is 9 cents per Kilowatt-hour, how much would your bill be?
- (48) If your utility bill indicates that you used 900 Kilowatt-Hours of electricity and the only electrical component you used was a 1,000 watt hair dryer - how many hours did you use it for?
- (49) What is meant by the words “*The China Syndrome*” relative to nuclear power? (*Note: Not the movie.*)
- (50) Why is the atmosphere inside an incandescent light bulb inert?